

SBL.08.327.100  
Revision: 01

## KAWASAKI KLE 500

### Schutzbügel Montagehinweise

Alle vom Motorrad gelösten Schrauben sind gemäß Herstellerangaben wieder zu montieren, oder mit von SW-MOTECH gelieferten Schrauben zu ersetzen. Falls nicht anderweitig definiert, diese Schrauben nach Tabelle anziehen.

M6	9,6 Nm
M8	23 Nm
M10	46 Nm

Gegebenenfalls Schrauben mit flüssiger Schraubensicherung einkleben.

Prüfen Sie nach 50 km alle Verbindungen auf festen Sitz.

SW-MOTECH GmbH & Co. KG  
Bahnhofstrasse 44d  
35282 Rauschenberg  
-Germany-

Tel.: ++ 49 (0) 6425 8168 00  
Fax: ++ 49 (0) 6425 8168 10

[www.sw-motech.com](http://www.sw-motech.com)



### Crash Bar Mounting Instructions

SW-MOTECH products should be installed by a qualified, experienced motorcycle technician. If you are unsure of your ability to properly install a product, please have the product installed by your local motorcycle dealer. SW-MOTECH takes no responsibility for damages caused by improper installation.

All screws, bolts and nuts, including all replacement hardware provided by SW-MOTECH, should be tightened to the torque specified in the OEM maintenance manual for your motorcycle. If no torque specifications are provided in the OEM maintenance manual, the following torques may be used:

M6	9,6 Nm
M8	23 Nm
M10	46 Nm

All screws, bolts and nuts should be checked after driving the first 50 km to ensure that all are tightened to the proper torque.

Medium strength liquid thread-locker (i.e., "Loctite") should be used to secure all screws, bolts and nuts.

1 **Schutzbügel**  
Crash Bar

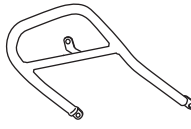

SBL.08.327.901/902  
Anzahl/ Pcs. 2 (L/R)

2 **Zylinderschraube mit Innensechskant**  
Hexagon Socket

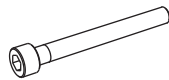

M10 x 300 DIN 912  
Anzahl/ Pcs. 1

3 **Unterlegscheibe**  
Washer



A 10,5 DIN 125  
Anzahl/ Pcs. 1

4 **Mutter mit Bund**  
Locking Nut



M10 DIN 6927  
Anzahl/ Pcs. 1

5 **Anbautraverse**  
Bracket

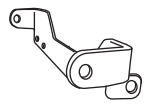

SBL.08.327.001  
Anzahl/ Pcs. 1

6 **Sechskantschraube**  
Hexagon Screw

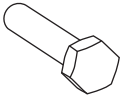

M10 x 1,25 x 35 DIN 961  
Anzahl/ Pcs. 1

7 **Unterlegscheibe**  
Washer



A 10,5 DIN 125  
Anzahl/ Pcs. 1

8 **Bügelsschraube**  
Bowscrew

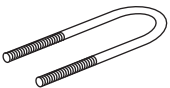

BUS.00.08.043.068.01  
Anzahl/ Pcs. 1

9 **Mutter mit Bund**  
Locking Nut



M8 DIN 6927/b  
Anzahl/ Pcs. 2

10 **Zylinderschraube mit Innensechskant**  
Hexagon Socket

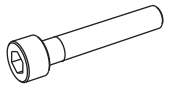

M8 x 25 DIN 912  
Anzahl/ Pcs. 2

11 **Unterlegscheibe**  
Washer



A 8,4 DIN 125  
Anzahl/ Pcs. 2

12 **Mutter mit Bund**  
Locking Nut



M8 DIN 6927/b  
Anzahl/ Pcs. 2

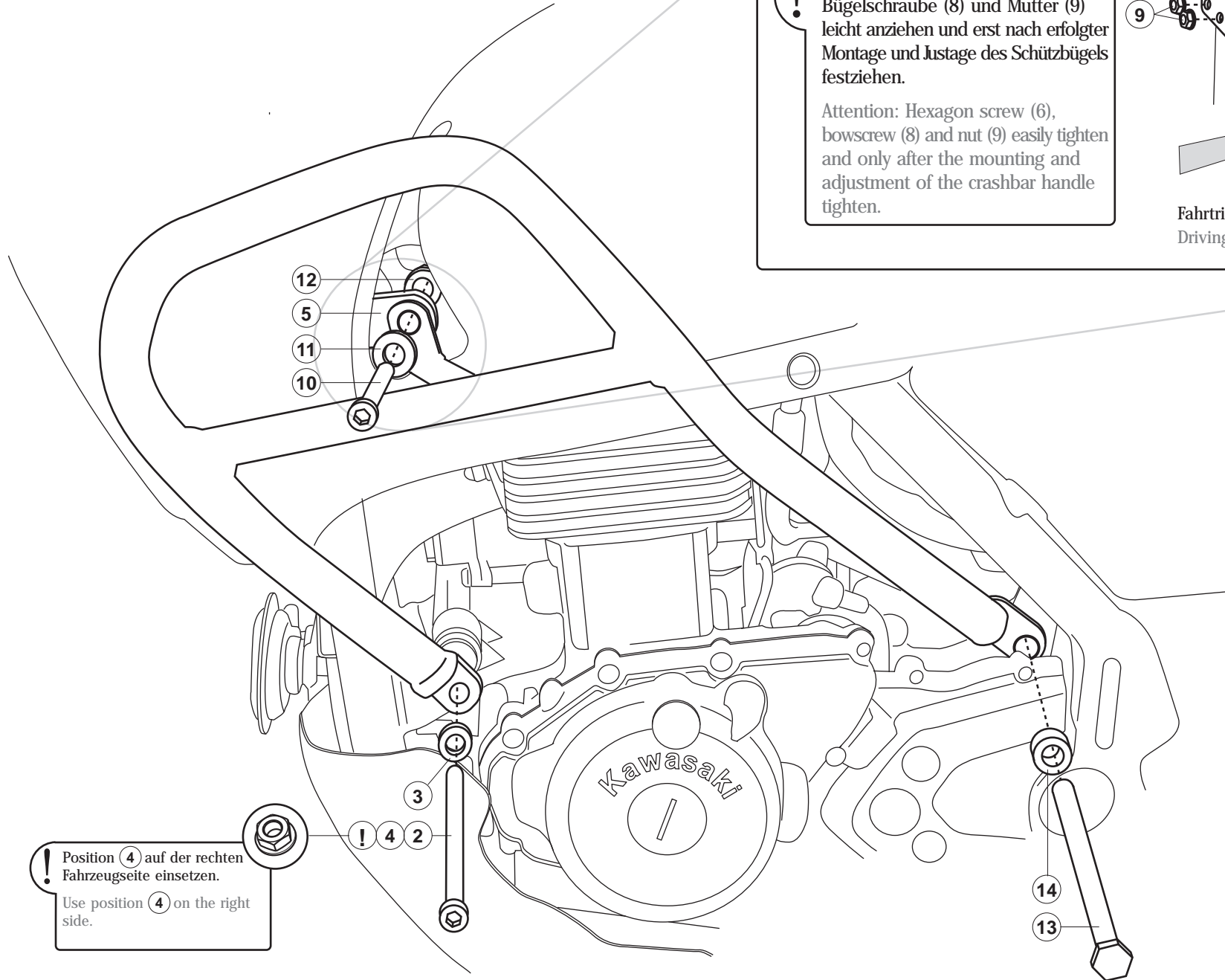

**!** Achtung: Sechskantschraube (6),  
 Bügelschraube (8) und Mutter (9)  
 leicht anziehen und erst nach erfolgter  
 Montage und Justage des Schützbügels  
 festziehen.

Attention: Hexagon screw (6),  
 bowscrew (8) and nut (9) easily tighten  
 and only after the mounting and  
 adjustment of the crashbar handle  
 tighten.

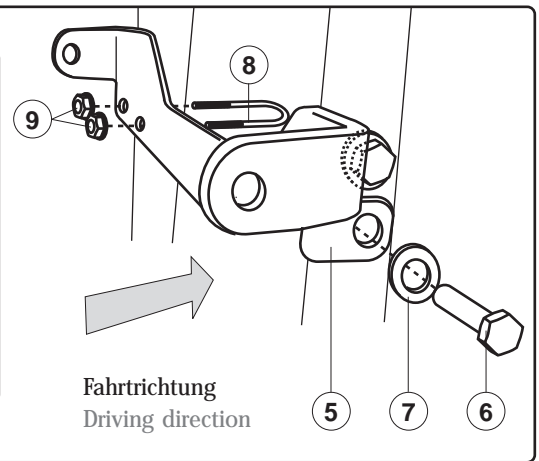

**!** Position (4) auf der rechten  
 Fahrzeugseite einsetzen.  
 Use position (4) on the right  
 side.

**13** Sechskantschraube  
 Hexagon Screw

M10 x 180    DIN 931

Anzahl/ Pcs.    1

**14** Distanzbuchse  
 Spacer

Da:20 Di:10,5 h:6

Anzahl/ Pcs.    1

